



INTEK®



MDA Series Spindle Servo Drives & Motors

г. Нижний Новгород
info@reduktor.nnov.ru
+7-831-223-82-00

MDA

AC Spindle Servo Drives / 380V, 0.4-160 kW

- V/F Control, SFVC, FVC Control Mode
- Controls AC Induction, Spindle Asynchronous Motor
- Support Various Optional Encoder
- Easy and flexible control; MODBUS RS485
- Incredible Performance of Speed, torque and position control; All protection



MDA series spindle servo drives is designed for numerical control machine of new type and high precision and it has new functions like positioning control, pulse synchronous control and so on. It supports FEEDBACK vector control towards the spindle motor with encoder. This drive has high responding ability towards speed as well as smooth speed. It can achieve various functions like warrant stop of spindle; Rigid tapping; indexing positioning and so on by cooperating with different numerical control system.

Features

Multi encoder support; it can support differential encoder; ABZ encoder and so on.

Power dip ride-through, load feedback energy compensates for any voltage reduction, allowing the drive to continue to operate for a short time during power dips.

Overvoltage and overcurrent stall control; the system limits the output current and voltage automatically during operation to prevent frequent or excessive trips.

Torque limit and control: the system limits the torque automatically to prevent frequent over-current tripping during operation. Torque control is applied in vector control.

Onboard multiple preset position: the system implements up to 16 position by using simple PLC function or by using digital input signals.

Item	Specifications	
Control Mode	V/F Control, Sensorless Vector Control, Closed-Loop Vector Control	
Motor Types	3 Phase Induction Motor	Spindle Asynchronous Motor
Max. Frequency	V/F control mode	0-1500 Hz
	Vector control mode	0-1000 Hz
Carrier Frequency	0.8-16.0 kHz Adjust the frequency automatically according to loading characteristics.	
Input Frequency Resolution	Digital Setting	0.01 Hz
	Analog Setting	Max. Frequency x 0.025%
Start Torque	G Type - 0.5 Hz / 150% (SFVC) / 0.0 Hz / 180% (FVC)	
Speed setting Range	1:100 SFVC	1:1000 FVC
Speed Stability Accuracy	±0.5%, SFVC	±0.2%, FVC
Overload Capacity	G Type	60s for 150%; 3s for 180% of rated current
	P Type	60s for 120%; 3s for 150% of rated current
Torque Boost	Auto-boost; Manuals adjust range	0.1%~30.0%
V/F Curve	Linear/ Multi-Point and N-th Power V/F Curve	
Ramp Mode	Straight Line Ramp; 4 Groups of Acceleration/Deceleration time 0.0-6500.0s	
DC Braking	DC Braking Frequency	0.0Hz to Max. frequency
	Braking Time	0.0s~36.0s
	Braking Action Current Value	0.0%~100.0%
Simple PLC, Multiple Preset Speed	It Implements up to 16 Speeds via the Simple PLC Function or Combination of Terminal States	
Auto voltage regulation (AVR)	It Can Keep Constant Output Voltage Automatically when the Mains Voltage Changes	
Overvoltage/ Overcurrent Stall Control	The current and voltage are limited automatically during the running process so as to avoid frequent tripping due to overvoltage/over current.	
Rapid Current Limit	It can decrease the over-current fault on a maximum extent, thus protecting the normal operation of the spindle servo driver.	
Torque Limit and Control	It can limit the torque automatically and prevent frequent over current tripping during the running process. Can be adjusted through FVC control mode.	
Optional support PG cards	Differential input PG card	Open collector
	Rotating transformer PG card	
Running Command Channel	Given by the Panel, Control Terminals, Serial Communication Port, can be switched by many ways.	
Auxiliary Frequency Source	Multiple Auxiliary frequency source. Flexible realization of auxiliary frequency fine-tuning and frequency synthesis	
Timing set	0.0-6500.0 min.	
Communication	ModBus RS485	
Input Terminal	6 Digital Input terminal 2 Analog Input Terminals, 1 of Which Only Supports 0-10V and the Other Supports 0-10V or 4-20mA	
Output Terminal	1 Digital Output Terminal	MO1
	2 Relay Output Terminal	RA, RB, RC, YA, YB, YC
	1 Analog Output Terminal, That Supports 0-20mA	
	Current Output or 0-10V Voltage Output	
Protection Function	Output phase loss, overcurrent, overvoltage, undervoltage, overheat, overload protections, etc.	

TYPICAL APPLICATION

CNC lathe, turn-milling machine tool, vertical lathe, Heavy duty horizontal lathe
Drilling and tapping center, engraving and milling machine, gear hobbing machine, gear shaping machine, gear milling machine



Dimension, mm

380V ±15% 3 Phase	Power Range, kW	W	H	H1	D	A	B	Ød
	0.4							
	0.75							
	1.5	74	222	250	163	/	237	5.5
	2.2							
3.7								

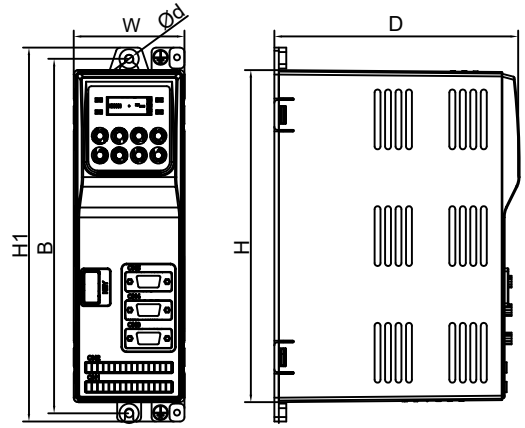

380V ±15% 3 Phase	Power Range, kW	W	H	H1	D	A	B	Ød
	5.5	89	235	260	200	/	250	5.5
	7.5							
	11	136	235	260	202	80	250	5.5
	15							
	18.5	193	235	260	222	132	250	5.5
	22							
	30	177	439	475	256	120	460	7.0
	37							
	45	239	579	615	308	160	600	9.0
	55							
	75							
	90	279	600	630	340	200	612	9.0
	110							
	132	305	845	880	450	200	838	11
160								

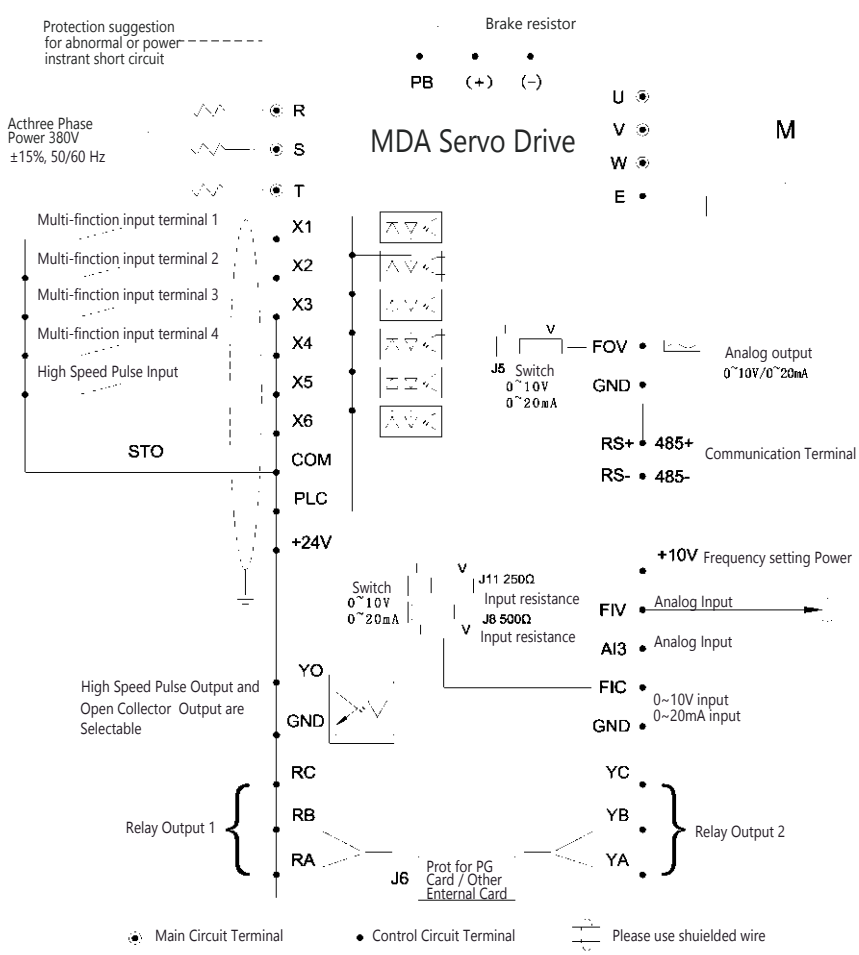
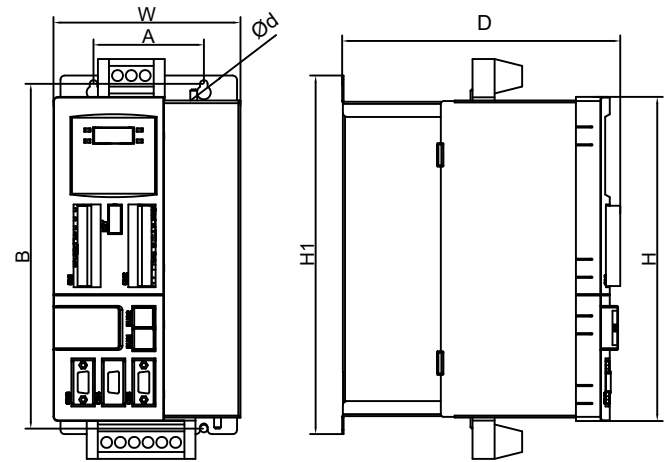

380V 3 Phase	Power Range, kW	Rated Input Current, A	Rated Output Current, A
	0.4	89	89
	0.75	89	89
	1.5	89	89
	2.2	89	89
	3.7	10.0	9.0
	5.5	15.0	13.0
	7.5	20.0	17.0
	11	26.0	25.0
	15	35.0	32.0
	18.5	38.0	37.0
	22	46.0	45.0
	30	26.0	89
	37	26.0	89
	45	26.0	89
55	26.0	89	
75	26.0	89	
90	26.0	89	
110	26.0	89	
132	26.0	89	
160	26.0	89	

SPECIFICATION

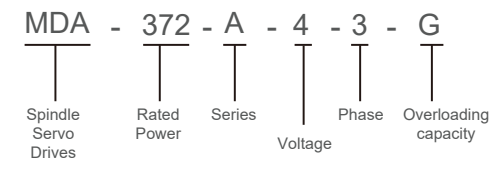

ASSM series AC spindle induction servo motor has a compact structure, superior function, good shape and high efficiency, widely used in various fields of machinery manufacturing with very good cost performance.



AC Spindle Induction Servo Motor

ASSM series is high power density of ac induction servo motor makes them perfect for industrial tools equipments, such as in machine tools, printing presses, or metal forming, flux vector type controllers in variable speed applications. The distinctive electromagnetic and mechanical design permits operation in constant power mode at maximum speeds of up to 24000 RPM. The efficient stator cooling system uses an auxiliary electrofan to combine the benefits of reduced dimensions and high, continuous, low-speed torque capability.

Advantage and Features

- Three-phase, 4 pole star winding with no access to neutral squirrel-cage rotor
- Power range 0.75 315 kW
- Max. speed 3,000 ... 24,000 rpm
- Encoder systems for a wide and diverse range of applications
- Construction with low losses laminated sheet
- Square form, compact, high, top speed capability
- Thermal protection by thermostat embedded in stator winding
- High overload capability
- Protection class IP55
- Insulation class F
- Works environment, degree : -15 ~ +45

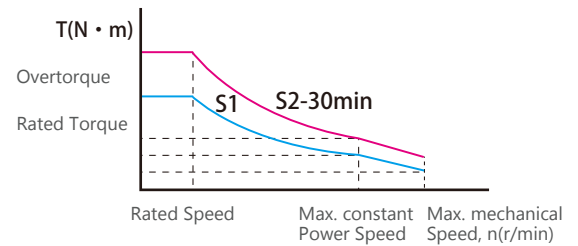
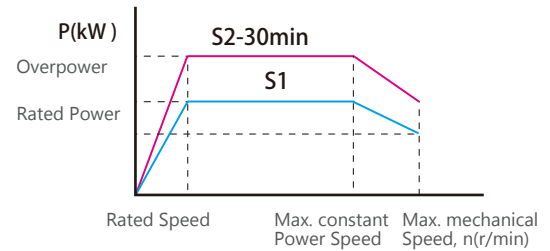

NAMING RULES

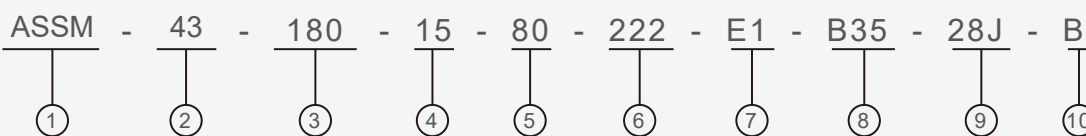

1 Products Series

AC Induction Spindle Servo Motor

2 Power Supply

- 43 - 380V, 3 phase
- 23 - 220V, 3 phase

3 Flange size

180 - 180 mm

4 Rated Speed

- 07 - 750 r/min
- 15 - 1500 r/min

5 Max. Speed

- 40 - 4000 r/min
- 120 - 12 000 r/min

6 Power

- 222 - 2.2 kW
- 402 - 4.0 kW

7 Type of Encoder

- E1 - Incremental 1024
- E2 - Incremental 2500
- R1 - Rotary 1024
- Z2 - Cosine 2048
- N - Non Encoder

8 Type of Mount

- B3 - Horizontal
- B5 - Vertical

9 Type of Output Shaft

- 28 - Shaft's Diameter
- J - with Keys
- G - Flat

10 Brake

- B - with Brake
- Blank - Non Brake

Model	Power, kW		Speed r/min			Voltage	Current, A		Torquet, N.m		Rotational Inertia kgm ²	Frame
	Continuous Rating	Overload in 30 min.	Rated Speed	Max. Constant Power speed	Max. Mechanical Power speed	Rated Voltage	Rated	Overcurrent in 30 min.	Rated	Overtorque in 30 min.		
ASSM-43-130S-15-60-751-*.**	0.75	1.1	1500	6000	10000	380	1.9	2.7	4.8	7	0.0019	130S
ASSM-43-130M-15-60-112-*.**	1.1	1.5					2.7	3.7	7	9.6	0.0027	130M
ASSM-43-130L-15-60-152-*.**	1.5	2.2					3.7	5.4	9.6	14	0.0035	130L
ASSM-43-130H-15-60-222-*.**	2.2	3					5.4	7.4	14	19.1	0.0050	130H

Dimension, mm

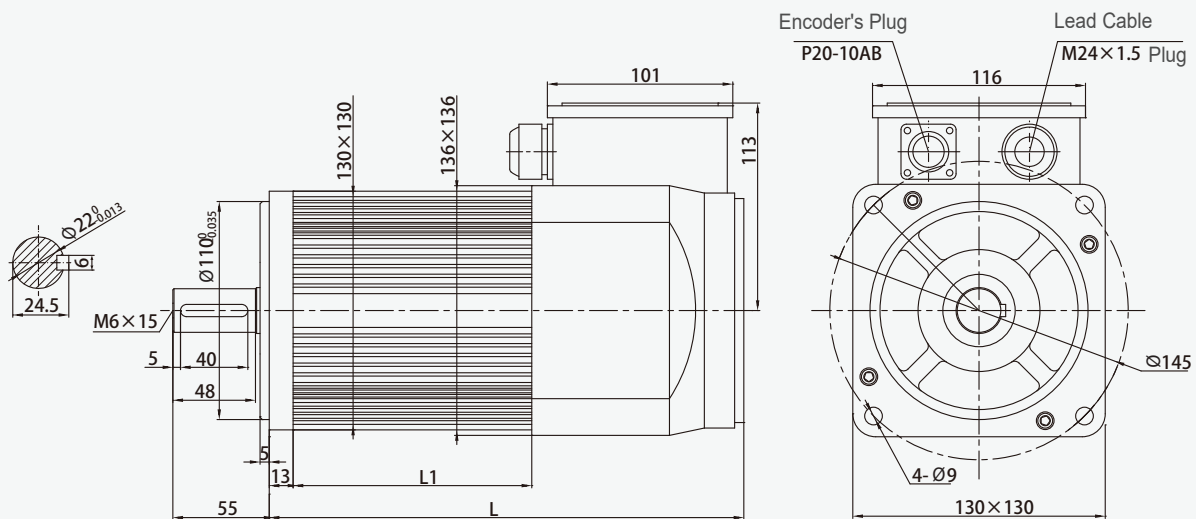

FLAME	L	L1
130S	263.5	135
130M	293.5	165
130L	323.5	195
130H	383.5	255

165 series ASSM

Model	Power, kW		Speed r/min			Voltage	Current, A		Torquet, N.m		Rotational Inertia kgm ²	Frame
	Continuous Rating	Overload in 30 min.	Rated Speed	Max. Constant Power speed	Max. Mechanical Power speed	Rated Voltage	Rated	Overcurrent in 30 min.	Rated	Overtorque in 30 min.		
ASSM-43-165S-7.5-40-751—*.*.*	0.75	1.1	750	3000	4000	380	1.83	2.64	9.6	14	0.0058	165S
ASSM-43-165M-7.5-40-112—*.*.*	1.1	1.5					2.64	3.53	14	19.1	0.0077	165M
ASSM-43-165N-7.5-40-152—*.*.*	1.5	1.8					3.53	4.28	19.1	22.9	0.0101	165N
ASSM-43-165L-7.5-40-182—*.*.*	1.8	2.2					4.28	5.2	22.9	28	0.0116	165L
ASSM-43-165H-7.5-40-222—*.*.*	2.2	3.7					5.2	8.6	28	48	0.0162	165H
ASSM-43-165S-10-60-751—*.*.*	0.75	1.1	1000	4000	6000	380	1.9	2.7	7.2	10.5	0.0058	165S
ASSM-43-165M-10-60-112—*.*.*	1.1	1.5					2.7	3.5	10.5	14.3	0.0077	165M
ASSM-43-165N-10-60-152—*.*.*	1.5	2.2					3.5	5.1	14.3	21	0.0101	165N
ASSM-43-165L-10-60-222—*.*.*	2.2	3.7					5.1	8.5	21	35.3	0.0116	165L
ASSM-43-165H-10-60-372—*.*.*	3.7	5.5					8.5	12	35.3	52.5	0.0162	165H
ASSM-43-165S-15-80-152—*.*.*	1.5	2.2	1500	6000	8000	380	3.8	5.1	9.6	14	0.0058	165S
ASSM-43-165M-15-80-222—*.*.*	2.2	3.7					5.1	8.2	14	23.6	0.0077	165M
ASSM-43-165N-15-80-302—*.*.*	3	4					6.6	8.8	19.1	35	0.0101	165N
ASSM-43-165L-15-80-402—*.*.*	4	5.5					8.8	12.2	25.5	35	0.0116	165L
ASSM-43-165H-15-80-552—*.*.*	5.5	7.5					12.2	15.4	35	48	0.0162	165H

Dimension, mm

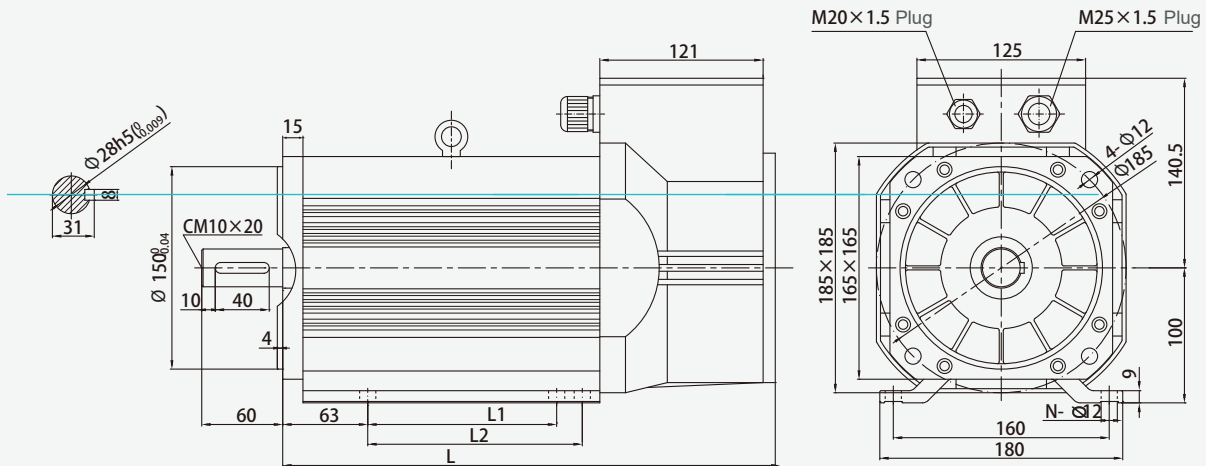

FLAME	L	L1	L2	N
165S	310	70	/	4
165M	335	95	112	6
165N	365	140	159	6
165L	385	140	159	6
165H	445	200	219	6

Model	Power, kW		Speed r/min			Voltage	Current, A		Torque, N.m		Rotational Inertia kgm ²	Frame
	Continuous Rating	Overload in 30 min.	Rated Speed	Max. Constant Power speed	Max. Mechanical Power speed	Rated Voltage	Rated	Overcurrent in 30 min.	Rated	Overtorque in 30 min.		
ASSM-43-180M-7.5-40-222-*.~.*	2.2	4	750	3000	4000	380	5	9	28	51	0.0151	180L
ASSM-43-180M-10-60-222-*.~.*	2.2	4	1000	4000	6000	380	5	8.2	21	38	0.0101	180M
ASSM-43-180L-10-60-402-*.~.*	4	5.5					8.2	12	38	52.5	0.0151	180L
ASSM-43-180S-15-80-222-*.~.*	2.2	4	1500	6000	8000	380	5	7.7	14		0.0071	180S
ASSM-43-180M-15-80-402-*.~.*	4	5.5					7.7	11.9	25.5		0.0101	180M
ASSM-43-180L-15-80-552-*.~.*	5.5	7.5					11.9	15.4	35	48		180L

Dimension, mm

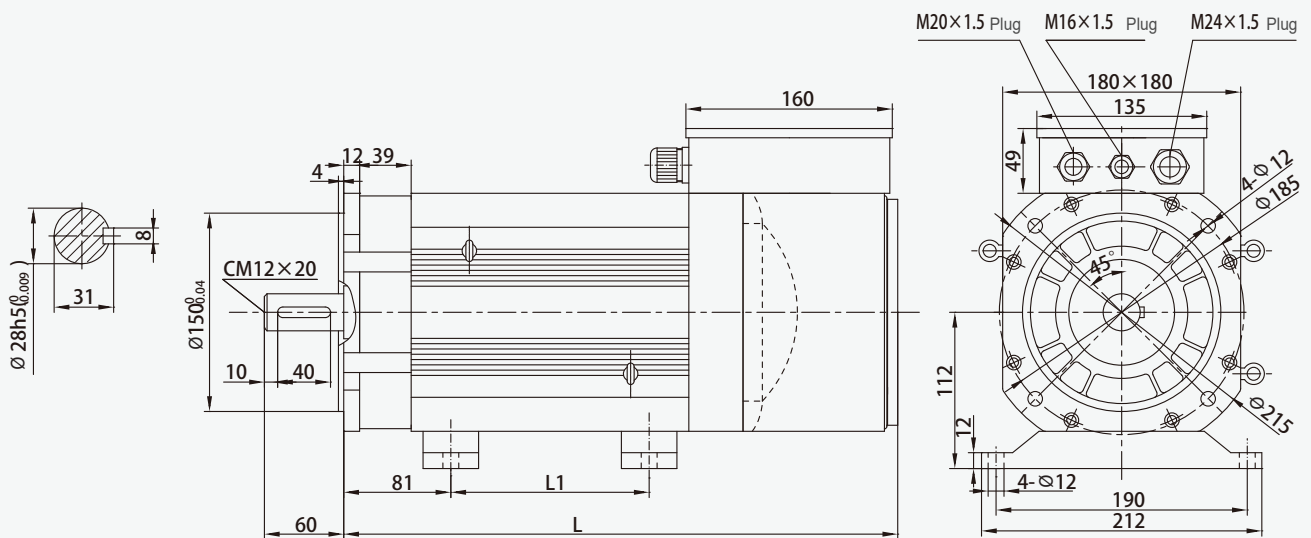

FLAME	L	L1
180S	334	65
180M	369	100
180L	419	150

200 series ASSM

Model	Power, kW		Speed r/min			Voltage Rated Voltage	Current, A		Torquet, N.m		Rotational Inertia kgm ²	Frame
	Continuous Rating	Overload in 30 min.	Rated Speed	Max. Constant Power speed	Max. Mechanical Power speed		Rated	Overcurrent in 30 min.	Rated	Overtorque in 30 min.		
ASSM-43-200M-7.5-40-222—*.*.*	2.2	4	750	3000	4000	380	5	9	28	51	0.0169	200M
ASSM-43-200L-7.5-40-402—*.*.*	4	5.5					9	12.3	51	70	0.0236	200L
ASSM-43-200H-7.5-40-552—*.*.*	5.5	7.5					12.3	15.3	70	95.5	0.0303	200H
ASSM-43-200M-10-60-402—*.*.*	4	5.5	1000	4000	6000	380	8.2	12	38	52.5	0.0169	200M
ASSM-43-200L-10-60-552—*.*.*	5.5	7.5					12	16.1	52.5	71.6	0.0236	200L
ASSM-43-200H-10-60-752—*.*.*	7.5	11					16.1	22.1	71.6	105	0.0303	200H
ASSM-43-200S-15-80-402—*.*.*	4	5.5	1500	6000	8000	380	8.4	11.7	25.5	35	0.0128	200S
ASSM-43-200M-15-80-552—*.*.*	5.5	7.5					11.7	15.4	35	48	0.0169	200M
ASSM-43-200L-15-80-752—*.*.*	7.5	11					15.4	22.7	48	70	0.0236	200L
ASSM-43-200H-15-80-113—*.*.*	11	15					22.7	29.1	70	95.5	0.0303	200H

Dimension, mm

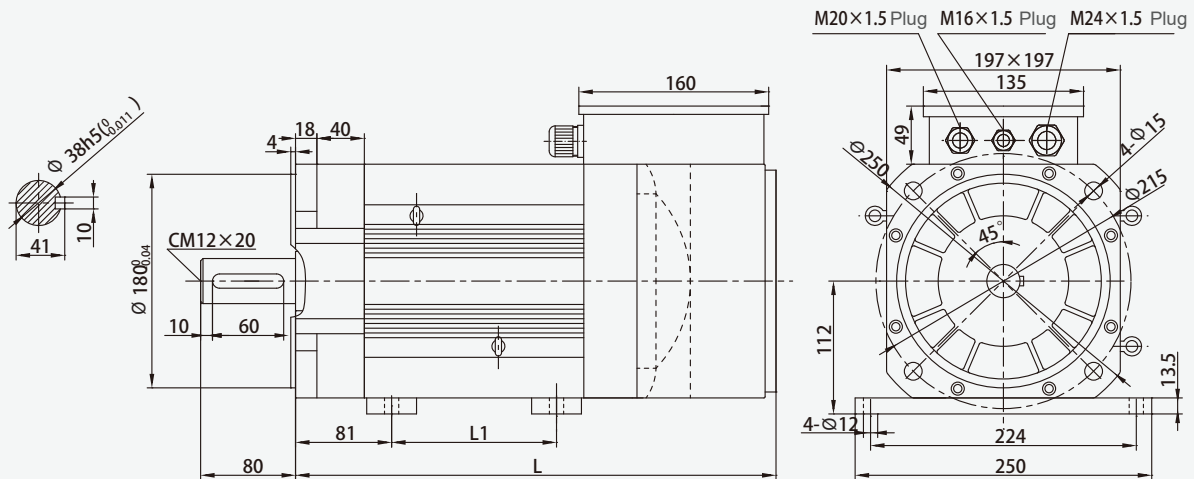

FLAME	L	L1
200S	375	109
200M	405	139
200L	455	189
200H	505	239

Model	Power, kW		Speed r/min			Voltage	Current, A		Torquet, N.m		Rotational Inertia kgm ²	Frame
	Continuous Rating	Overload in 30 min.	Rated Speed	Max. Constant Power speed	Max. Mechanical Power speed	Rated Voltage	Rated	Overcurrent in 30 min.	Rated	Overtorque in 30 min.		
ASSM-43-265S-7.5-30-552-*.**.*	5.5	7.5	750	2250	3000	380	11.6	15.3	70	96	0.0605	265S
ASSM-43-265M-7.5-30-752-*.**.*	7.5	9					15.3	18.4	96	115	0.0791	265M
ASSM-43-265L-7.5-30-902-*.**.*	9	11					18.4	22.1	115	140	0.0954	265L
ASSM-43-265H-7.5-30-113-*.**.*	11	13					22.1	26.1	140	166	0.1117	265H
ASSM-43-265E-7.5-30-133-*.**.*	13	15					26.1	29.9	166	191	0.135	265E
ASSM-43-265F-7.5-30-153-*.**.*	15	18.5					29.9	32.6	191	236	0.1676	265F
ASSM-43-265S-10-40-752-*.**.*	7.5	11	1000	3000	4000	380	15.3	22.1	72	105	0.0605	265S
ASSM-43-265M-10-40-113-*.**.*	11	13					22.1	25.9	105	124	0.0791	265M
ASSM-43-265L-10-40-133-*.**.*	13	15					25.9	29.6	124	143	0.0954	265L
ASSM-43-265H-10-40-153-*.**.*	15	18.5					29.6	36.3	143	177	0.1117	265H
ASSM-43-265E-10-40-183-*.**.*	18.5	22					36.3	42.8	177	210	0.135	265E
ASSM-43-265F-10-40-223-*.**.*	22	26					42.8	45.5	210	248	0.1676	265F
ASSM-43-265S-15-60-113-*.**.*	11	15	1500	4500	6000	380	21.6	29.1	70	96	0.0605	265S
ASSM-43-265M-15-60-153-*.**.*	15	18.5					29.1	35.7	96	118	0.0791	265M
ASSM-43-265L-15-60-183-*.**.*	18.5	22					35.7	42	118	140	0.0954	265L
ASSM-43-265H-15-60-223-*.**.*	22	26					42	49.3	140	166	0.1117	265H
ASSM-43-265E-15-60-263-*.**.*	26	30					49.3	56.5	166	191	0.135	265E
ASSM-43-265F-15-60-303-*.**.*	30	37					56.5	63.3	191	236	0.1676	265F

Dimension, mm

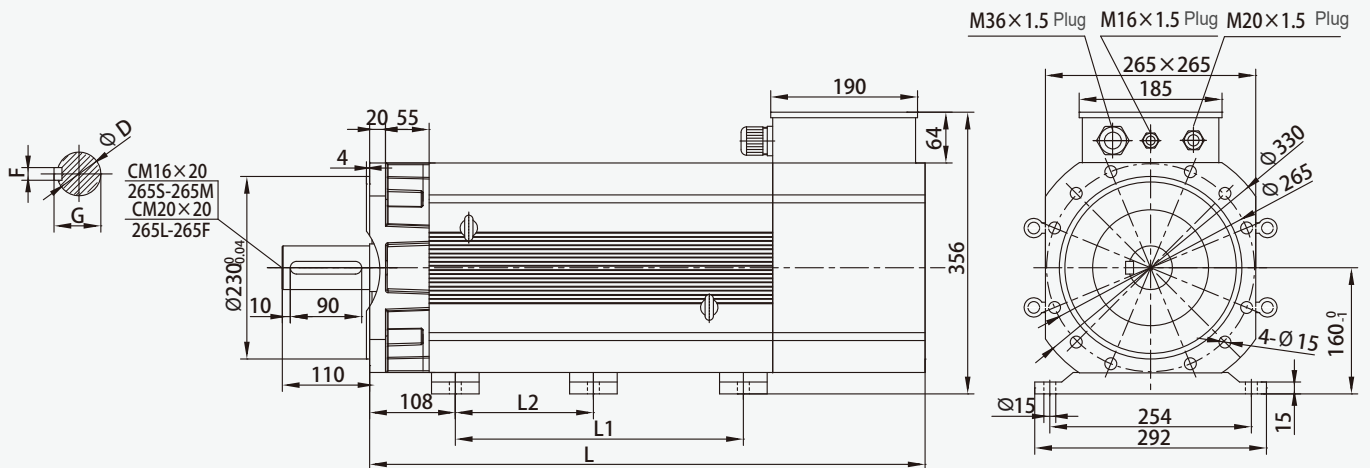

FLAME	L	L1	L2	D	F	G
265S	482	133	/	42h5 ⁰ _(-0.011)	12	45
265M	510	173	/	42h5 ⁰ _(-0.011)	12	45
265L	545	208	/	55h5 ⁰ _(-0.013)	16	59
265H	580	243	/	55h5 ⁰ _(-0.013)	16	59
265E	630	293	/	55h5 ⁰ _(-0.013)	16	59
265F	700	363	174	55h5 ⁰ _(-0.013)	16	59

360 series ASSM

Model	Power, kW		Speed r/min			Voltage Rated Voltage	Current, A		Torque, N.m		Rotational Inertia kgm ²	Frame
	Continuous Rating	Overload in 30 min.	Rated Speed	Max. Constant Power speed	Max. Mechanical Power speed		Rated	Overcurrent in 30 min.	Rated	Overtorque in 30 min.		
ASSM-43-360S-7.5-30-153-*.**.*	15	18.5	750	1800	3000	380	29.4	35.9	191	236	0.2979	360S
ASSM-43-360M-7.5-30-183-*.**.*	18.5	22					35.9	43.7	236	280	0.3724	360M
ASSM-43-360L-7.5-30-223-*.**.*	22	26					43.7	53	280	331	0.4469	360L
ASSM-43-360H-7.5-30-303-*.**.*	30	37					61	72.5	382	471	0.5362	360H
ASSM-43-360E-7.5-30-373-*.**.*	37	45					72.5	88.2	471	573	0.6405	360E
ASSM-43-360S-10-40-223-*.**.*	22	26	1000	2500	4000	380	41.9	50.4	210	248	0.2979	360S
ASSM-43-360M-10-40-263-*.**.*	26	30					50.4	57.9	248	287	0.3724	360M
ASSM-43-360L-10-40-303-*.**.*	30	37					57.9	70.3	287	353	0.4469	360L
ASSM-43-360H-10-40-373-*.**.*	37	45					70.3	87.2	353	430	0.5362	360H
ASSM-43-360E-10-40-453-*.**.*	45	55					87.2	105	430	525	0.6405	360E
ASSM-43-360S-15-45-303-*.**.*	30	37	1500	3600	4500	380	56	68.5	191	236	0.2979	360S
ASSM-43-360M-15-45-373-*.**.*	37	45					68.5	84.1	236	287	0.3724	360M
ASSM-43-360L-15-45-453-*.**.*	45	55					84.1	103.6	287	350	0.4469	360L
ASSM-43-360H-15-45-553-*.**.*	55	75					103.6	139.8	350	478	0.5362	360H
ASSM-43-360E-15-45-753-*.**.*	75	90					139.8	167	478	573	0.6405	360E

Dimension, mm

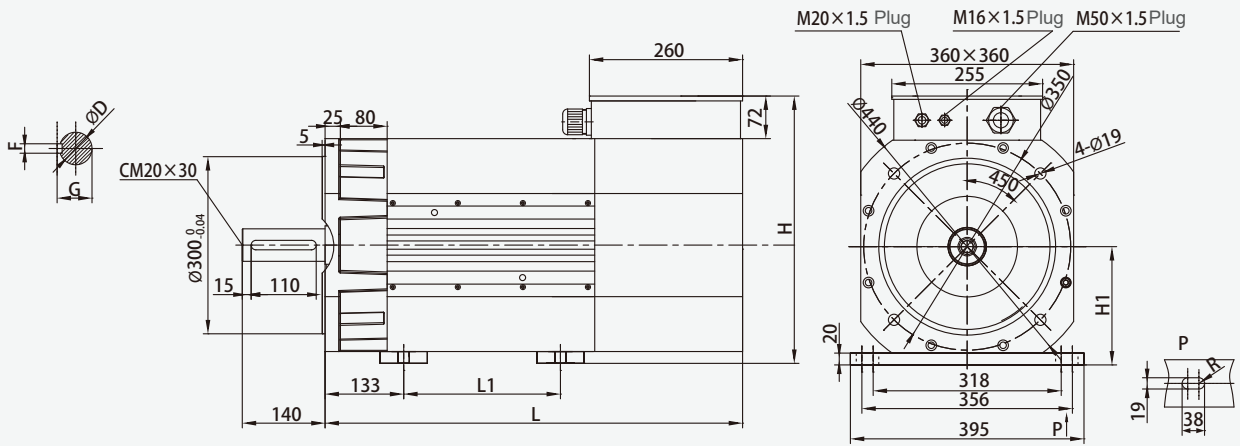

FLAME	L	L1	H	H1	D	F	G
360S	713	265	452	200	55h5 (⁰ _{-0.013})	16	59
360M	763	315	477	225	55h5 (⁰ _{-0.013})	16	59
360L	813	365	477	225	60h5 (⁰ _{-0.013})	18	64
360H	873	425	477	225	60h5 (⁰ _{-0.013})	18	64
360E	943	495	477	225	60h5 (⁰ _{-0.013})	18	64

Model	Power, kW		Speed r/min			Voltage	Current, A		Torque, N.m		Rotational Inertia kgm ²	Frame
	Continuous Rating	Overload in 30 min.	Rated Speed	Max. Constant Power speed	Max. Mechanical Power speed	Rated Voltage	Rated	Overcurrent in 30 min.	Rated	Overtorque in 30 min.		
ASSM-43-500S-7.5-30-453—*.*.*	45	55	750	1800	3000	380	83.1	101.2	573	700	1.7479	500S
ASSM-43-500M-7.5-30-553—*.*.*	55	70					101.2	130	700	891	2.1225	500M
ASSM-43-500L-7.5-30-653—*.*.*	65	75					120	140.4	828	955	2.6219	500L
ASSM-43-500H-7.5-30-753—*.*.*	75	90					140.4	166.3	955	1146	2.934	500H
ASSM-43-500E-7.5-30-903—*.*.*	90	110					166.3	201	1146	1401	3.3085	500E
ASSM-43-500S-10-40-553—*.*.*	55	75	1000	2500	4000	380	99.8	136.9	525	716	1.7479	500S
ASSM-43-500M-10-40-753—*.*.*	75	90					136.9	163.9	716	860	2.1225	500M
ASSM-43-500L-10-40-903—*.*.*	90	110					163.9	201.1	860	1051	2.6219	500L
ASSM-43-500H-10-40-114—*.*.*	110	132					201.1	240.4	1051	1261	2.934	500H
ASSM-43-500E-10-40-134—*.*.*	132	145					240.4	289.6	1261	1528	3.3085	500E
ASSM-43-500S-15-40-903—*.*.*	90	110	1500	3600	4000	380	162.2	198.5	573	700	1.7479	500S
ASSM-43-500M-15-40-114—*.*.*	110	132					198.5	238.4	700	840	2.1225	500M
ASSM-43-500L-15-40-134—*.*.*	132	160					238.4	286.3	840	1018	2.6219	500L
ASSM-43-500H-15-40-164—*.*.*	160	185					286.3	330	1018	1178	2.934	500H
ASSM-43-500E-15-40-184—*.*.*	185	200					330	390	1178	1401	3.3085	500E

Dimension, mm

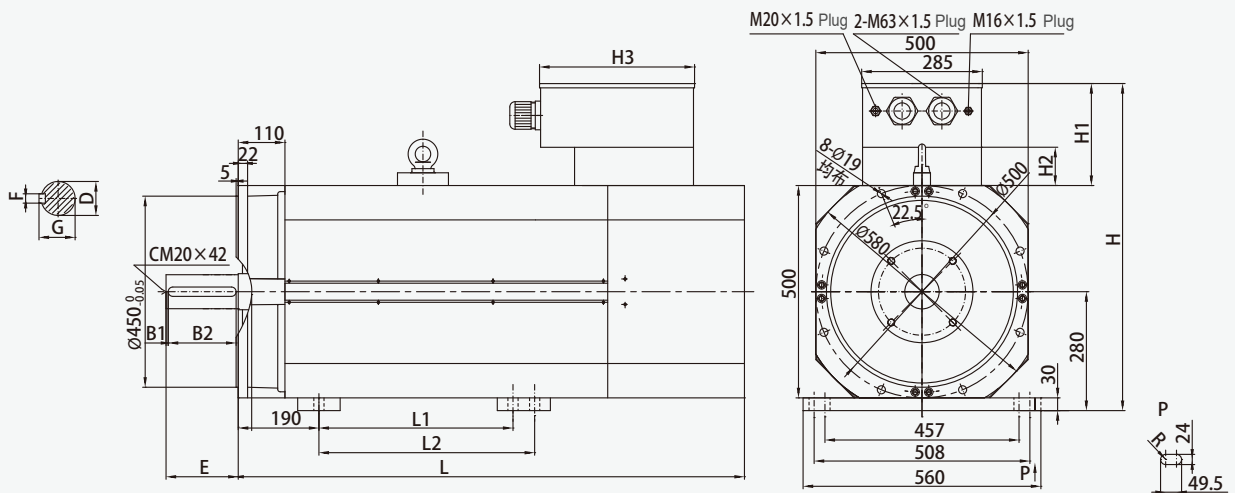

FLAME	D	G	F	E	L1	L2	L	B1	B2	H	H1	H2	H3
500S	Ø75m6 (+0.030/+0.011)	79.5	20	140	368	/	932	7.5	125	630	100	/	280
500M	Ø75m6 (+0.030/+0.011)	79.5	20	140	419	/	992	7.5	125	770	240	90	365
500L	Ø80m6 (+0.030/+0.011)	85	22	170	457	/	1082	5	160	770	240	90	365
500H	Ø80m6 (+0.030/+0.011)	85	22	170	457	508	1132	5	160	770	240	90	365
500E	Ø80m6 (+0.030/+0.011)	85	22	170	457	508	1192	5	160	770	240	90	365

620 series ASSM

Model	Power, kW		Speed r/min			Voltage	Current, A		Torquet, N.m		Rotational Inertia kgm ²	Frame
	Continuous Rating	Overload in 30 min.	Rated Speed	Max. Constant Power speed	Max. Mechanical Power speed	Rated Voltage	Rated	Overcurrent in 30 min.	Rated	Overtorque in 30 min.		
ASSM-43-620S-7.5-30-903—*.*.*	90	110	750	1500	2500	380	165	200	1146	1401	5.0886	620S
ASSM-43-620M-7.5-30-114—*.*.*	110	132					200	240	1401	1681	6.0138	620M
ASSM-43-620L-7.5-30-134—*.*.*	132	160					240	285	1681	2037	6.8234	620L
ASSM-43-620H-7.5-30-164—*.*.*	160	185					285	327	2037	2356	7.8642	620H
ASSM-43-620S-10-30-134—*.*.*	132	160	1000	2000	3000	380	236	285	1261	1528	5.0886	620S
ASSM-43-620M-10-30-164—*.*.*	160	185					285	328	1528	1767	6.0138	620M
ASSM-43-620L-10-30-184—*.*.*	185	200					328	355	1767	1910	6.8234	620L
ASSM-43-620H-10-30-204—*.*.*	200	250					355	438	1910	2388	7.8642	620H
ASSM-43-620S-15-30-204—*.*.*	200	250	1500	3000	3000	380	348	434	1273	1592	5.0886	620S
ASSM-43-620M-15-30-254—*.*.*	250	280					434	488	1592	1783	6.0138	620M
ASSM-43-620L-15-30-284—*.*.*	280	315					488	545	1783	2006	6.8234	620L
ASSM-43-620H-15-30-314—*.*.*	315	355					545	615	2006	2260	7.8642	620H

Dimension, mm

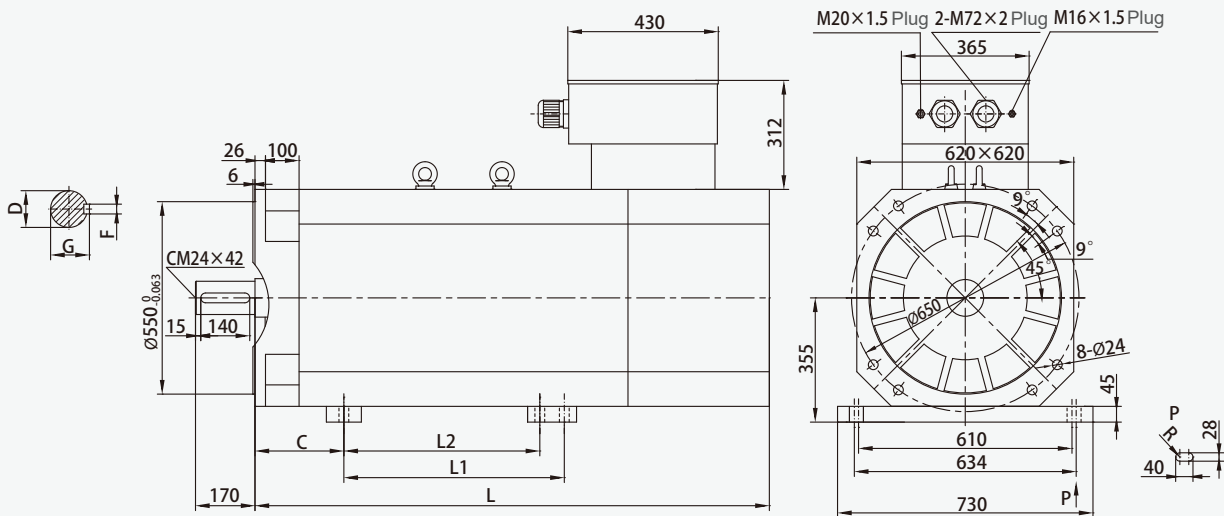

FLAME	D	G	F	C	L2	L1	L
620S	Ø80m6(+0.030/+0.011)	85	22	216	457	508	1230
620M	Ø80m6(+0.030/+0.011)	85	22	216	457	508	1310
620L	Ø95m6(+0.035/+0.013)	100	25	254	500	560	1380
620H	Ø95m6(+0.035/+0.013)	100	25	254	560	630	1470

Компания Редуктор

Г. Нижний Новгород, ул. Зайцева 31, оф. 508

Тел./факс +7 (831) 223-81-81

E-mail: info@reduktor.nnov.ru

Сайт: www.reduktor.nnov.ru